

Bridge-Mounted Drive Units

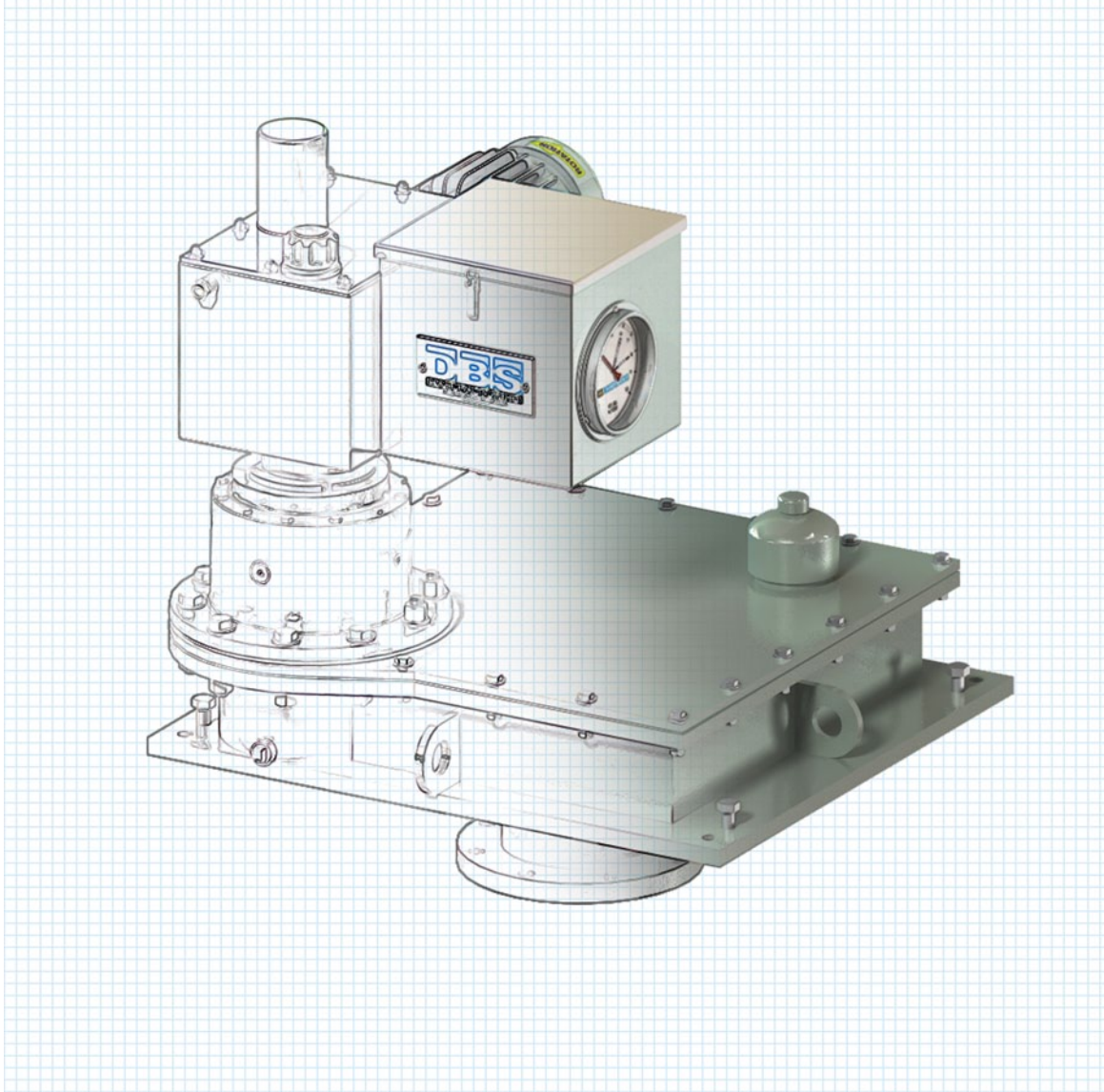

DBS MANUFACTURING®

Bridge-Mounted Drive Units

Description

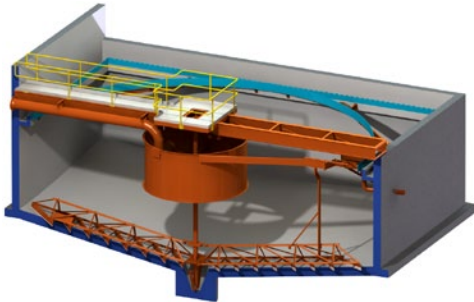

- A low-speed, high-torque, totally enclosed gear drive with positive overload protection
- The drive unit is supported by a bridge completely spanning the tank
- The drive unit has a central output shaft to drive the rakes
- Used in industrial, municipal and mining clarifiers and thickeners
- Typically used on tank sizes from 10 to 100 ft (3 to 30 m) in diameter

Features



- Forged alloy steel main gear and pinion designed for 20 years of life calculated per AGMA 2001-C95
- Precision, four-point-contact main bearing, with a 10-year warranty
- Accurate torque gauge calibrated in ft-lbf, N-m or any units desired
- Alarm and cutoff switches and maximum torque limiting via shear pin or pressure relief valve
- No lower pinion bearing, eliminating a common source of drive failure
- Designed for minimum maintenance with permanently lubricated intermediate reducer

TORQUE CAPACITIES - BRIDGE-MOUNTED DRIVE UNITS

Model	Continuous		Maximum Overload		Yield	
	ft-lbf	N-m	ft-lbf	N-m	ft-lbf	N-m
SX-A*	3,000	4,100	6,000	8,200	8,100	11,000
SX-B*	6,000	8,200	12,000	16,400	16,200	22,000
SX-C*	10,000	14,000	20,000	28,000	27,000	36,500
S25-A*	14,000	19,000	28,000	38,000	54,000	73,000
S34-A*	18,500	25,000	37,000	50,000	120,000	163,000
S34-B*	27,000	36,500	54,000	73,000	120,000	163,000
S44-B*	35,000	47,500	70,000	95,000	195,000	264,000
S44-C*	51,000	69,000	102,000	138,000	195,000	264,000
S60-C*	65,000	88,000	130,000	176,000	440,000	597,000
S60-D*	125,000	169,500	250,000	339,000	440,000	597,000
S80-D*	140,000	190,000	280,000	380,000	750,000	1,017,000
S80-E*	250,000	339,000	500,000	678,000	750,000	1,017,000
S44-B*2	70,000	95,000	140,000	190,000	390,000	528,000
S44-C*2	102,000	138,000	204,000	276,000	390,000	528,000
S60-C*2	130,000	176,000	260,000	352,000	880,000	1,194,000
S60-D*2	250,000	339,000	500,000	678,000	880,000	1,194,000
S80-D*2	280,000	380,000	560,000	760,000	1,500,000	2,034,000
S80-E*2	500,000	678,000	1,000,000	1,356,000	1,500,000	2,034,000

Replace the * with the primary reducer option selected.

Continuous: Torque at which main gear will have a life in excess of 20 years at normal operating speeds.

Maximum Overload: The maximum safe, short term operating torque.

Yield: The structural maximum torque based on the minimum yield strength of the main gear.

Bridge-Mounted Drive Units

SX-Series Dimensions



- | Item | Description |
|------|-----------------------|
| 1 | Machine Frame |
| 2 | Planetary Gearbox |
| 3 | Torque Gauge Assembly |
| 4 | Primary Speed Reducer |
| 5 | Output Flange |

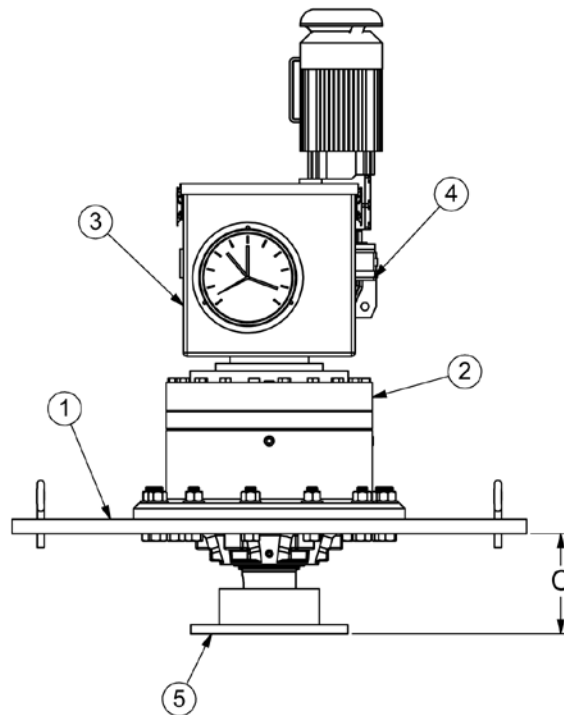
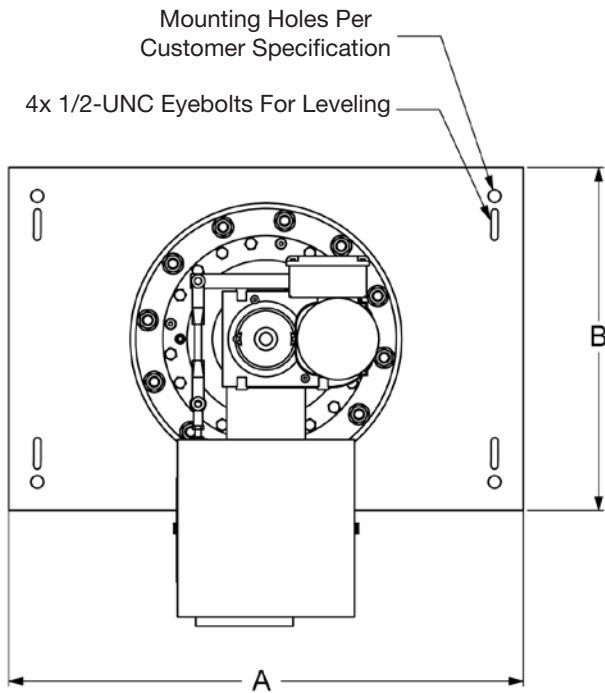

Model	A		B		C		Output Flange ¹	Weight	
	in	mm	in	mm	in	mm		lb	kg
SX-A*	36	914	24	610	5.2	132	4"	700	318
SX-B*	36	914	24	610	7	178	6"	900	410
SX-C*	36	914	24	610	8.6	218	6"	1,200	545

¹ Metric flanges are available.
Replace the * with the primary reducer option selected.

Bridge-Mounted Drive Units

S-Series Dimensions



- | Item | Description |
|------|-----------------------|
| 1 | Machine Frame |
| 2 | Main Gearbearing |
| 3 | Pinion |
| 4 | Planetary Gearbox |
| 5 | Primary Speed Reducer |
| 6 | Torque Gauge Assembly |
| 7 | Output Flange |
| 8 | Drain Plug |

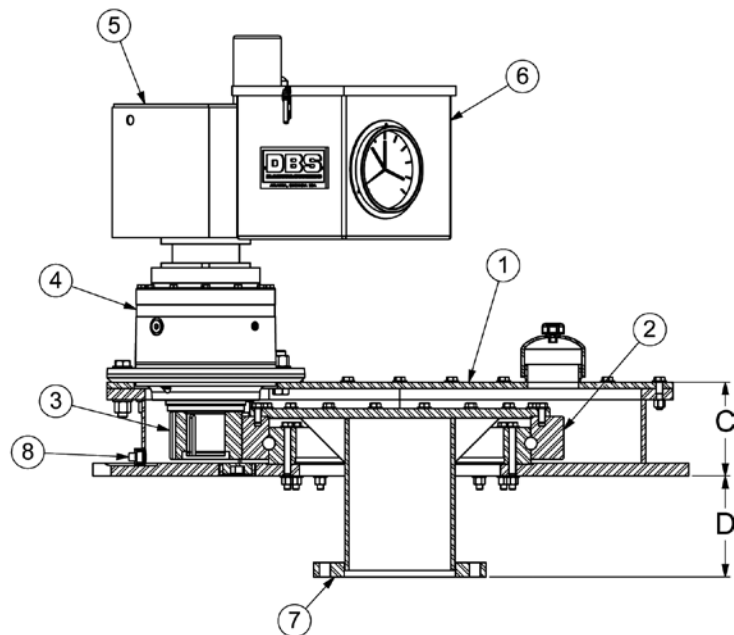
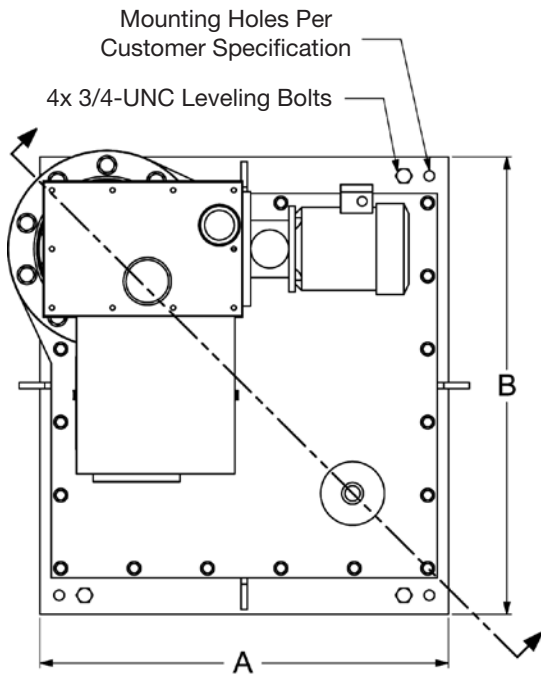

Model	A		B		C		D		Output Flange ¹	Weight	
	in	mm	in	mm	in	mm	in	mm		lb	kg
S25-A*	32	813	36	914	7.4	188	8	203	6"	1,340	610
S34-A*	39.5	1,003	43.5	1,105	8.1	207	8	203	8"	1,940	880
S34-B*	42.5	1,080	46.5	1,180	9.4	239	8	203	8"	2,340	1,060
S44-B*	50	1,270	55	1,397	9.3	236	10	254	10"	2,920	1,330
S44-C*	54	1,372	59	1,499	11.3	287	10	254	10"	3,500	1,590
S60-C*	66	1,676	70	1,778	11.5	292	12	305	18"	5,000	2,270
S60-D*	68	1,727	73	1,854	10.1	258	12	305	18"	5,600	2,540
S80-D*	96	2,438	104	2,642	13.5	343	14	356	24"	10,800	4,910

¹ Metric flanges are available.

Replace the * with the primary reducer option selected.

Bridge-Mounted Drive Units

Primary Reducer Option

W-Type



E-Type



F-Type



H-Type

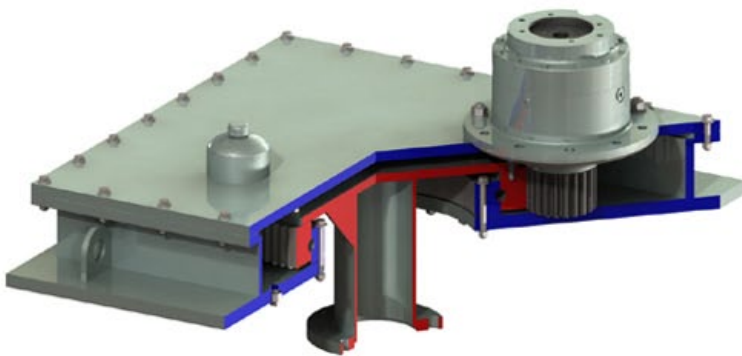
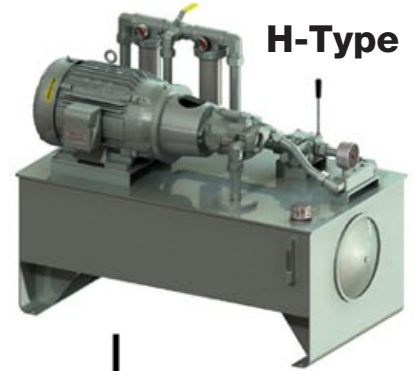

S-Series

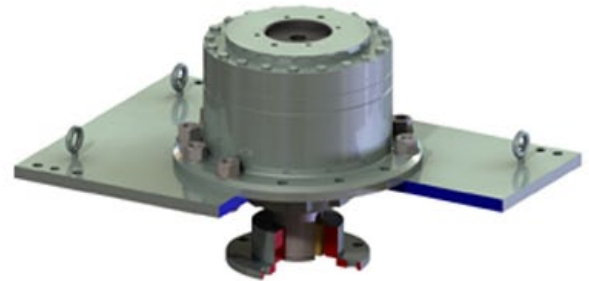

SX-Series

One of the items above will be used with one of the items below to make a complete drive unit assembly.

Bridge-Mounted Drive Units

Primary Reducer Option

E-type primary speed reducer

The E-type design uses helical gears for speed reduction. It has alarm and cutoff switches and a shear pin to provide triple protection of the drive unit. This design is used where the output speed is outside the limits of the F-type primary speed reducers or when an electro-mechanical type drive unit is desired.



F-type primary speed reducer

The F-type design uses a hydraulic pump-motor combination for speed reduction. It has alarm and cutoff switches and hydraulic relief (equivalent to a shear pin in the E-type primary speed reducer) to provide triple protection of the drive unit. This design is positive torque-limiting and will operate under stalled and semi-stalled conditions. Optional reversing rotation and variable speed are available. The torque indication and protection system is equally accurate for operation in either direction.

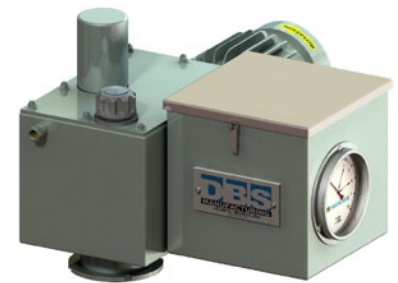

H-type primary speed reducer

The H-type design has all the features of the F-type primary speed reducer. It uses a stand-alone industrial hydraulic power unit. This design is used on higher horsepower and multiple pinion drive applications.



W-type primary speed reducer

The W-type design uses helical gears for speed reduction. It has shear pin and shear pin activated cutoff switch to protect the drive unit. This is simplified E-type design used where a torque gauge and adjustable alarm switch are not required.



Bridge-Mounted Drive Units

Lift Mechanism Option



The lift mechanism provides the ability to raise and lower the rakes. The rake lift operates by raising the output shaft into the drive unit. Rake vertical displacement of up to 36 inches (900 mm) can be provided.

The lift mechanism is fully contained within the drive unit. In most cases, the installation of a DBS lift-equipped drive unit is no more complicated than that of a normal non-lifting clarifier drive.

The lift option is offered with manual or powered operation. The powered lift mechanism provides positive lift force control to prevent damage to the rakes or the screw jack.

The DBS powered lift design does not require the lift mechanism to rotate. There are no rotary electrical slip rings to maintain.

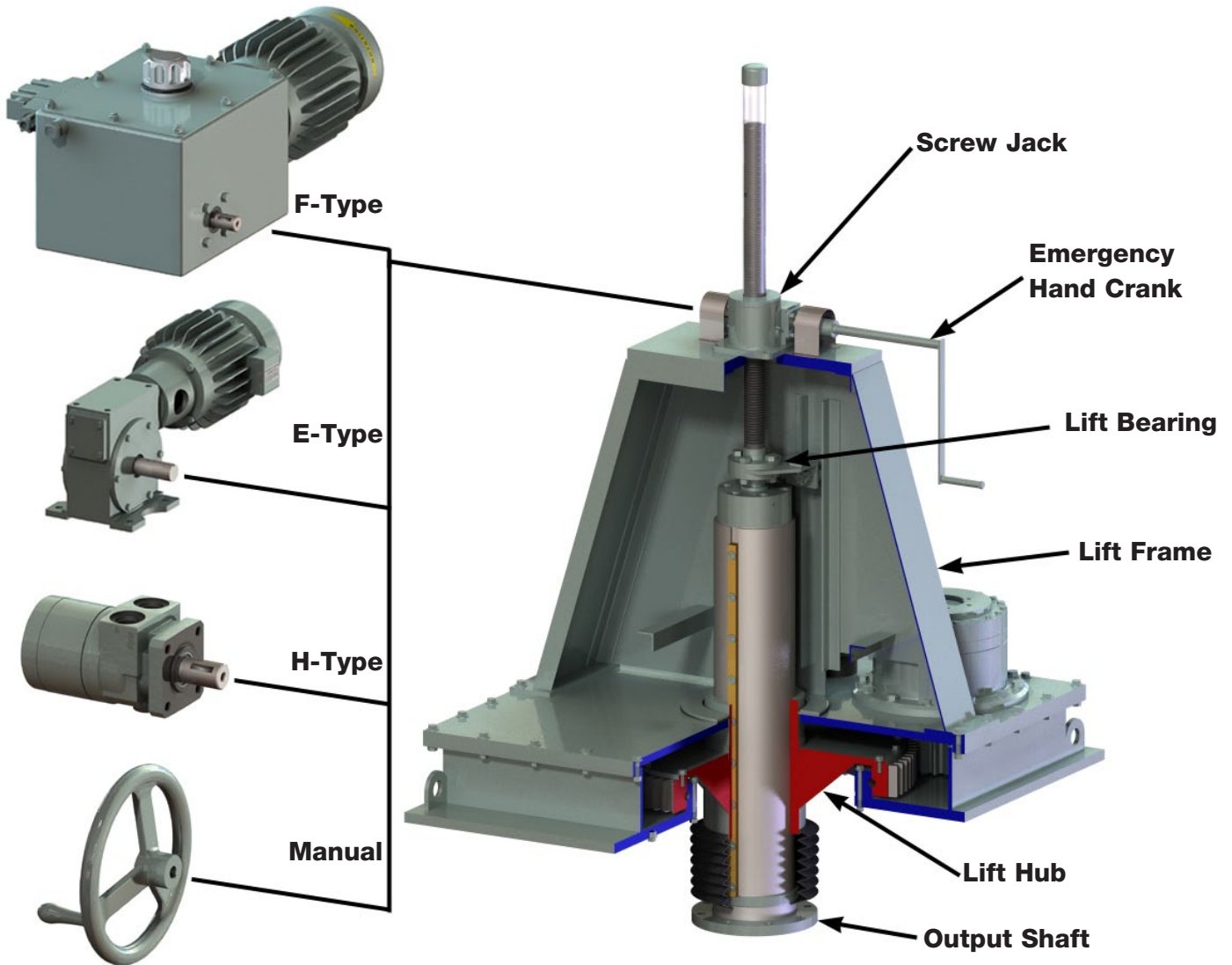

F-Type Lift Actuator: A totally enclosed hydraulic speed reducer power the lift jack.

E-Type Lift Actuator: The actuator utilizes a series of mechanical speed reducers to power the lift jack.

H-Type Lift Actuator: A hydraulic motor, powered by the rake primary reducer, operates the lift jack.

Bridge-Mounted Drive Units

Ordering Information

Bridge-Mounted Drive Unit Model Number					Lift Option Specification Extension					
Series	Rake Gear Pitch Dia. (inches)	-	Secondary Speed Reducer	Primary Speed Reducer	Number of Pinions	-	Lift Option	Lift Capacity (tons)	Lift Travel (inches)	Lift Actuator Option
S	X for no final gear-bearing		A	E	(N/A)		L	5	12	M, E, F
			B	F				24		
			C			(N/A)	(N/A)	(N/A)	(N/A)	
	25		A	E F H	1 (omit) 2	L	5	12	M E F H	
	34		A				10	24		
			B				15	36		
	44		B				15			
			C				20			
	60		C				25			
			D				35			
	80		D				Consult Factory	Consult Factory	Consult Factory	
			E							

Example: Model S34-AF-L1012F

S is for a bridge-mounted drive unit; 34 is the size of the final gear pitch diameter in inches; A is the size of the secondary speed reducer; F is the type of the primary reducer; L is for a lift mechanism; 10 is the lift capacity in tons; 12 is the lift travel in inches; F is the type of the lift actuator.

Standard Features

- Alarm and cutoff switches
- O&M manual in PDF format
- 6" torque gauge indicating real torque
(not available on H-type primary reducer)

Optional Features

- 4-20 mA torque transducer
- Bi-directional operation (available for F and H-type primary reducers)
- Loss motion switch
- 4-20 mA lift position transducer
- Variable speed
- Explosion proof switches
- Special coating
- Oil heater (available for F and H-type primary reducers and main gear housing)
- Special electric motor
- Oil temperature switch
- Oil level switch



**Bridge-Mounted Drive Units
Model S25-AF**

Clarifier & Thickener Drives

Retrofits

Low-Speed Surface Aerators

Rotary Distributor Center Mechanisms

DBS Manufacturing, Incorporated
45 SouthWoods Parkway, Atlanta, Georgia 30354 USA
404.768.2131 phone 404.761.6360 fax
www.dbsmfg.com email: engineering@dbsmfg.com